



# SAWA PARKING SYSTEMS

# TABLE OF CONTENTS

What is Sawa Parking Systems? _____	4
About the Company _____	4
Our Vision _____	5
Our Mission _____	5
Our Factory _____	6
Our Services _____	7
Single Post Car Parking Lift _____	8
Two Post Car Parking Lift _____	10
Tilting Platform Car Parking Lift _____	14
Four Post Car Parking Lift _____	16
Triple Stacker Car Parking Lift _____	18
Hydraulic Four Post Car / Cargo Elevator _____	20
Hydraulic Scissor Car / Cargo Elevator _____	22
Geared Motor Car / Cargo Elevator _____	26
Puzzle Car Parking System _____	28
Rotary Car Parking System _____	32
Car Space Block _____	34



# What is **SAWA** **Parking Systems?**

SAWA Parking Systems is a set of various parking solutions that allow vehicles to be parked vertically instead of spread laterally by a combination between mechanical means, classic controllers and automatic controllers such PLC.

SAWA Parking Systems allow more cars to park in the same area that save urban land spaces and help owners of various types of constructions to meet their needs and legal requirements for parking spaces even there is no enough area.

## About the Company

As a co-operation between a group of reputable Egyptian entities with foreign investors and as an extension to 8 years of experience in mechanical and automatic parking industry in more than 55 countries over the world and proceeding from our responsibility towards Egypt; our beloved country, came the big decision and **SAWA** factory was established in 2021 to be the first factory specialized in the manufacturing of mechanical parking systems in Egypt, Africa and Middle East.

On 7000 square meter in 10<sup>th</sup> of Ramadan city **SAWA** factory was established, equipped with latest manufacturing technologies and equipments such as laser cutting machine (table 6x2 m), bending machine tandem 6m and 3D laser drilling & cutting robot..etc

**SAWA** factory is being operated by a highly qualified staff of engineering experts, experienced technicians and professional support & administrative team.





# Our Vision

We took on our shoulders the responsibility to be the pioneers who lead the market in Egypt, Africa and Middle East to achieve our vision:

“A parking space for every car anytime anywhere”

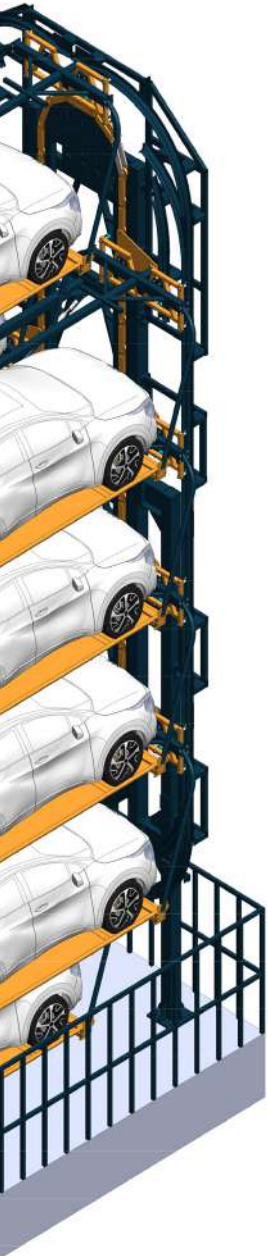

## Our Mission

- Cooperate with real estate developers, engineers, contractors and construction companies to effectively plan and design car parking spaces in new construction projects to meet needed requirements.
- Provide owners of residential, commercial and administrative buildings with the ideal solution for their parking problems due to high traffic by maximizing the capacity of parking spaces without neither using new land area nor building new construction.
- Provide complete service through planning, design, manufacturing, supply and installation of various types of our top-notch efficient and safe mechanical parking systems.

# Our Factory

SAWA Parking Systems mobilizes all its resources to provide Egyptian made top notch mechanical parking products through its factory at 10<sup>th</sup> of Ramadan and introduce them to the whole world.

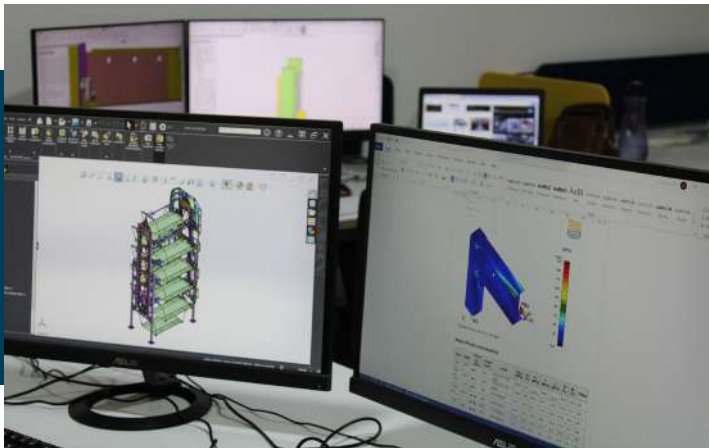

Expert design and R&D team with latest CAD/CAM/CAE systems.

Press brake (Bending) machine 6m, tandem with sheet follower.



Computerized fiber laser cutting machine for cutting metal plates in various sizes up to (6x2m).





Highly qualified electrical & automatic control team of engineers and technicians for electric panels assembly, automation and PLC programming.

High quality automatic welding machines with professional high-skilled technicians.



## Our Services

- Parking Spaces Planning.
- Parking Systems Design and R&D.
- Parking Systems Manufacturing.
- Supply & Installation.
- Maintenance & After Sales Services.



# Single Post Car Parking



SPL 2T1850

## PRODUCT FEATURES

- Driven by single stage hydraulic cylinder and chain with safety system that locked and released automatically.
- Compact size and streamlined design with no need for maneuvering area.
- Space saving with free entrance and exit. Ideal for use in corridors and aisles while we can park the car on the platform without blocking the road.
- Platform runway made of diamond steel plates, removable corrugated galvanized steel plates in the middle.
- Diamond steel ramps suitable for parking sports cars.
- The standard finishing is sandblasting then painting 2 layers (primer & finish coat) with SAWA standard colors (RAL 7015 Slate grey & RAL 1028 Melon yellow).

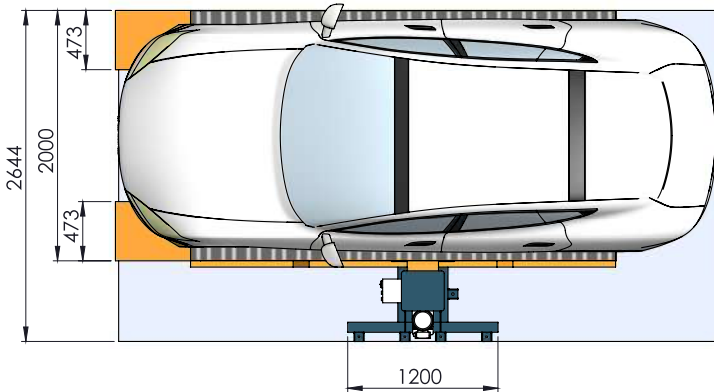
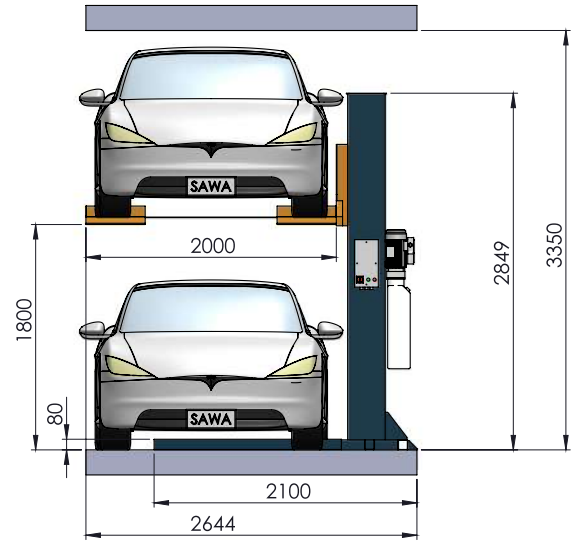
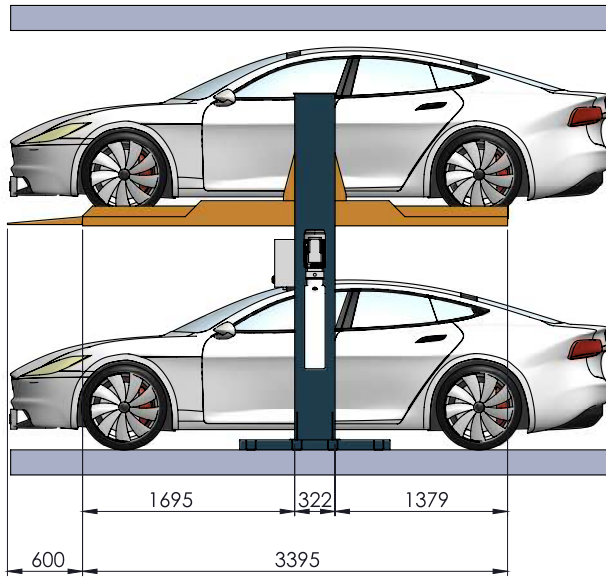

Model Type No.	Car Weight	Unit Height	Power Supply	Motor Capacity
SPL 2T1850	2000 Kg	2849 mm	220 V or 380 V	2.2 Kw

## Two Post Car Parking



TPL 2.7T2000

### PRODUCT FEATURES

- Hydraulic lifting system connected with chain to lift the platform and chain to balance the lifting system too.
- Driven by single stage dual hydraulic cylinders and chain with safety system that locked and released automatically that act as an Anti-falling mechanical locks to ensure safety.
- Contains a control panel with (UP, DOWN & EMERGENCY) buttons.
- High polymer polyethylene, wear-resistant slide blocks.
- Suitable for commercial and residential use. possibility to share posts for multiple connected units to save more space.
- lifting platform level could be customized for various car types according to ceiling height up to 2000 mm. (Min. ceiling height is 3.30 m).
- The standard finishing is sandblasting then painting 2 layers (primer & finish coat) with SAWA standard colors (RAL 7015 Slate grey & RAL 1028 Melon yellow).



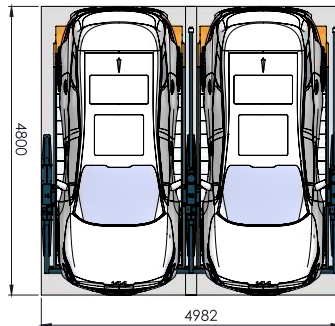
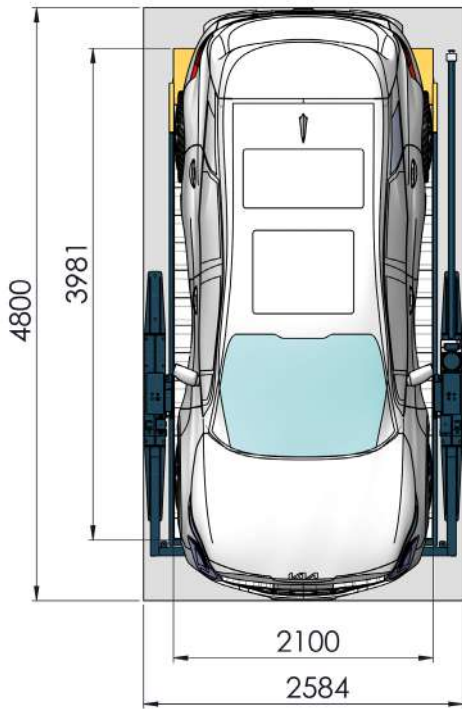
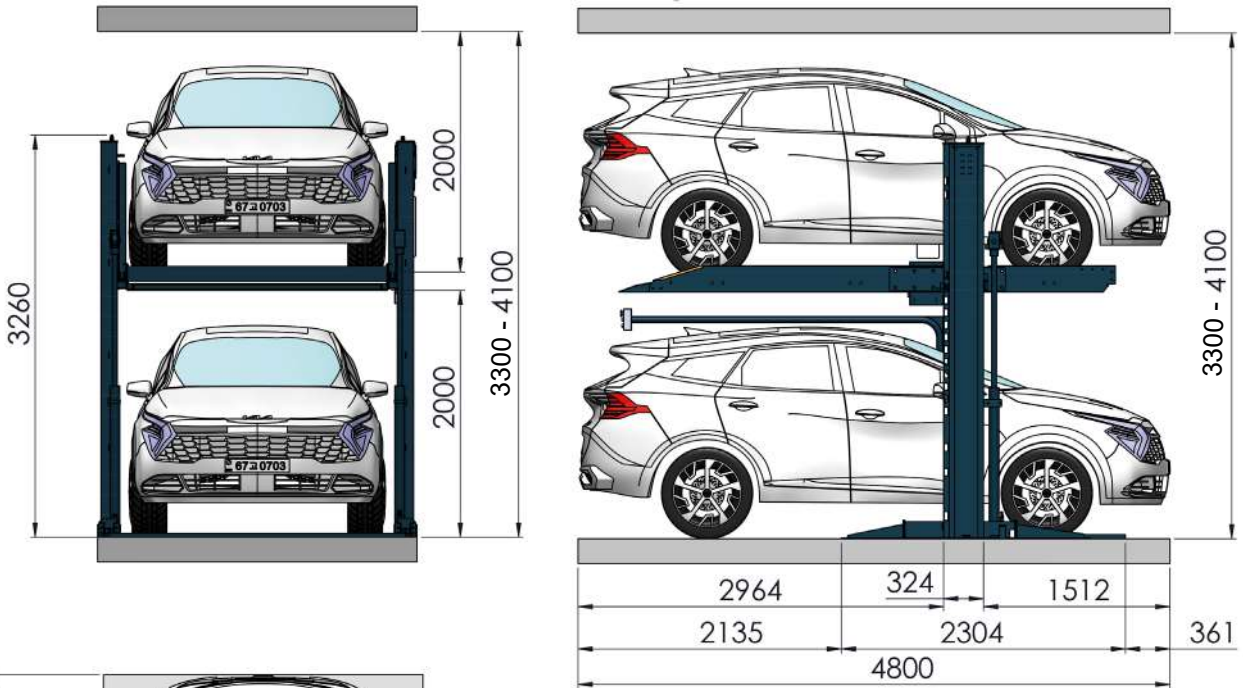

2 Units (Shared Column)

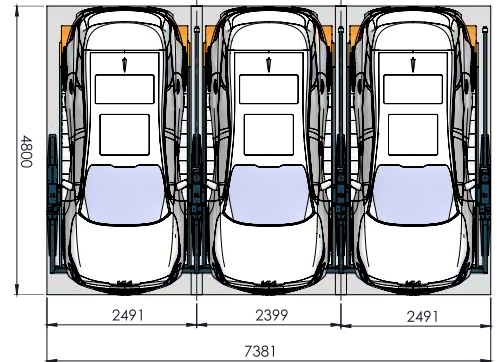

3 Units (Shared Column)

Model Type No.	Car Weight	Unit Height	Power Supply	Motor Capacity
TPL 2.7T2000	2700 Kg	3260 mm	220 V or 380 V	2.2 Kw

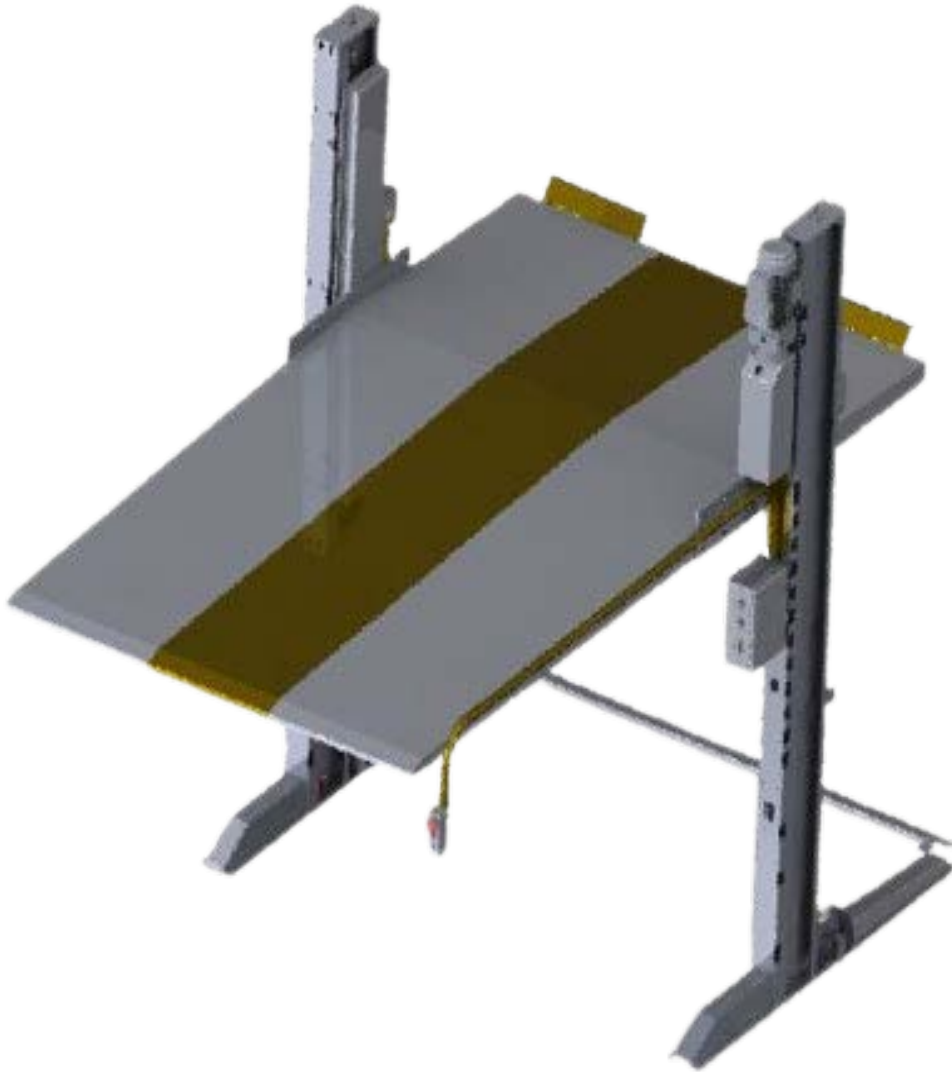

Two Post Parking Lift - sport cars special edition  
(The lowest ground - up to 8 cm)



Two Post Parking Lift - standard  
(Standard ground clearance 13cm )



# Tilting Car Parking



## PRODUCT FEATURES

- Driven by single stage dual hydraulic cylinders and chain with safety system that locked and released automatically.
- Automatic safety lock & electromagnetic lock release.
- Suitable for narrow garages with low ceiling height about 280 cm, and is suitable for sedan cars only.
- Adjustable platform angle to park different sedan cars.
- Balance shaft to ensure synchronous up & down movement.
- The standard finishing is sandblasting then painting 2 layers (primer & finish coat) with SAWA standard colors (RAL 7015 Slate grey & RAL 1028 Melon yellow).

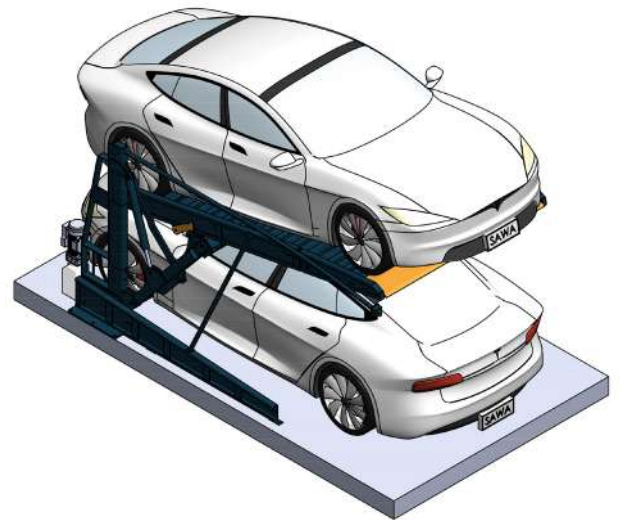
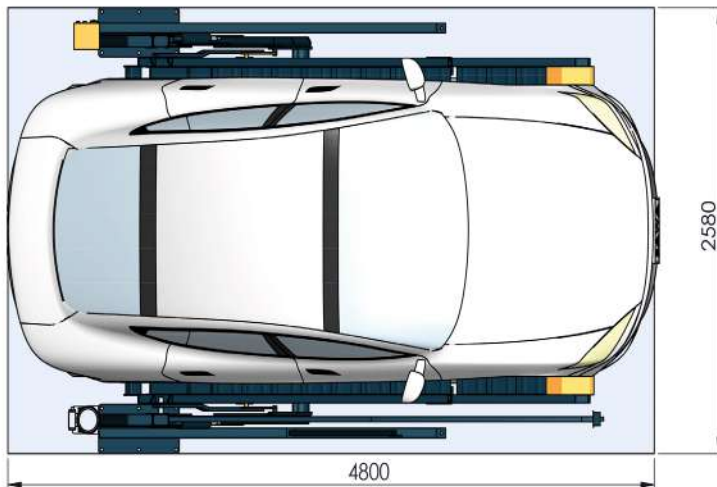
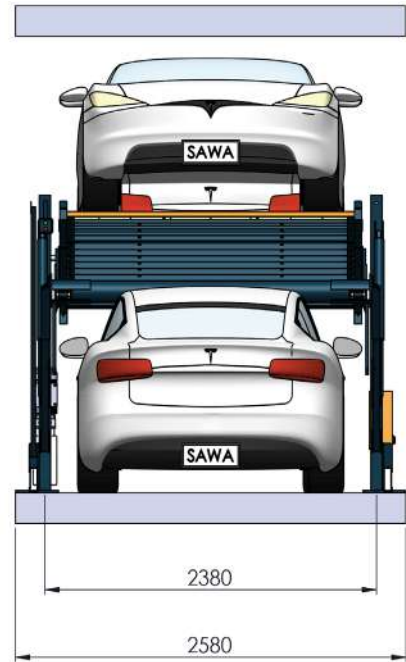
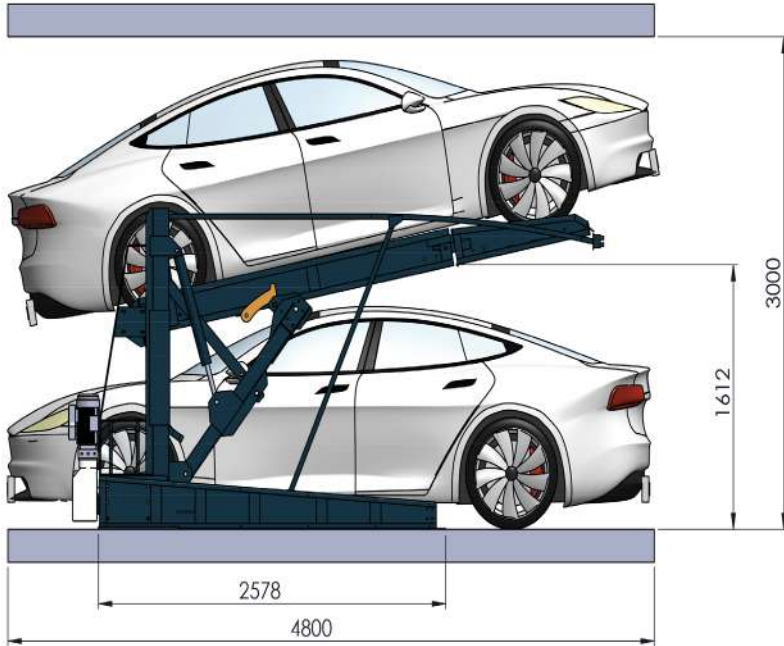

Model Type No.	Car Weight	Unit Height	Power Supply	Motor Capacity
TTL 2T1700	2000 Kg	1848 mm	220 V or 380 V	2.2 Kw

# Four Post Car Parking



## PRODUCT FEATURES

- Hydraulic lifting system with steel ropes.
- Driven by single stage one hydraulic cylinder.
- High polymer polyethylene, wear-resistant slide blocks.
- Platform runway and ramps are made of diamond steel plates.
- Movable galvanized steel plates in the middle.
- Anti-falling mechanical locks in four posts at different heights to ensure safety.
- The standard finishing is sandblasting then painting 2 layers (primer & finish coat) with SAWA standard colors (RAL 7015 Slate grey & RAL 1028 Melon yellow).



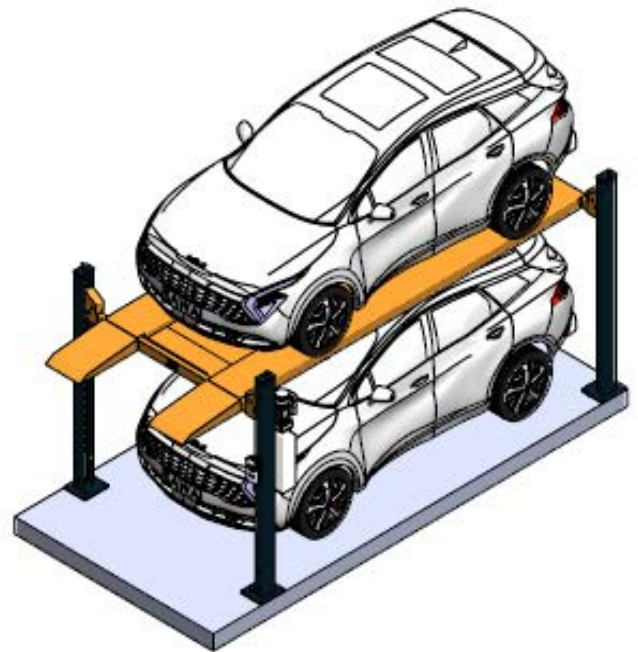
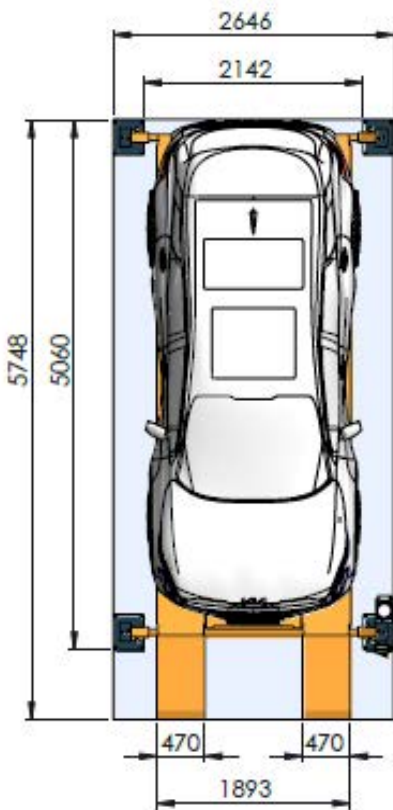
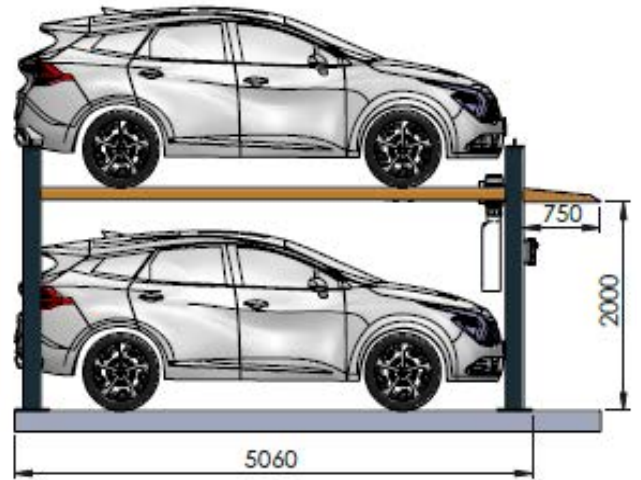
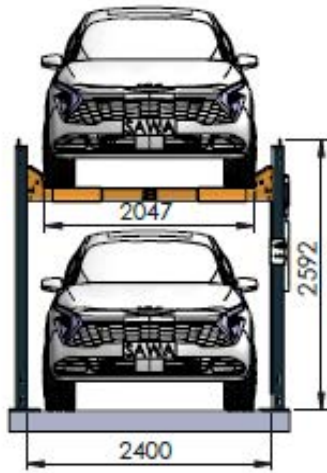

Model Type No.	Car Weight	Unit Height	Power Supply	Motor Capacity
FPL 2.7T2000	2700 Kg	2592 mm	220 V or 380 V	2.2 Kw

# Triple Stacker Car Parking



TSL 2.7T3500

## PRODUCT FEATURES

- Hydraulic driven cylinders with wire rope lifting system through sheaves.
- Double safety locks in each post: first is one-piece safety lock ladder and the other will be activated automatically in case of steel wire rupture.
- Ramps are suitable for sport cars and occupy less space.
- Automatic latch locking system inside ladders allows the release of the electromagnetic lock through the push-button in the operating box.
- Electric control panel and hydraulic power unit will be placed inside a compartment fixed to the front post.
- The standard finishing is sandblasting then painting 2 layers (primer & finish coat) with SAWA standard colors (RAL 7015 Slate grey & RAL 1028 Melon yellow).

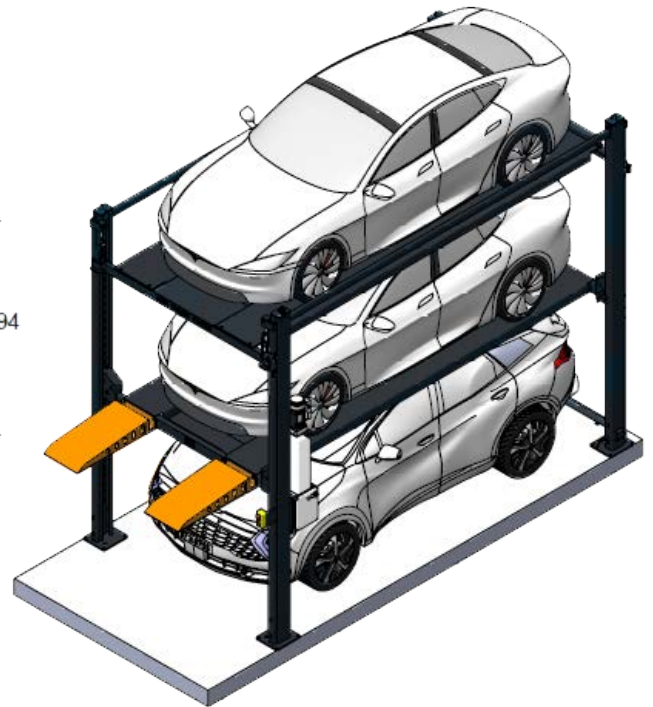
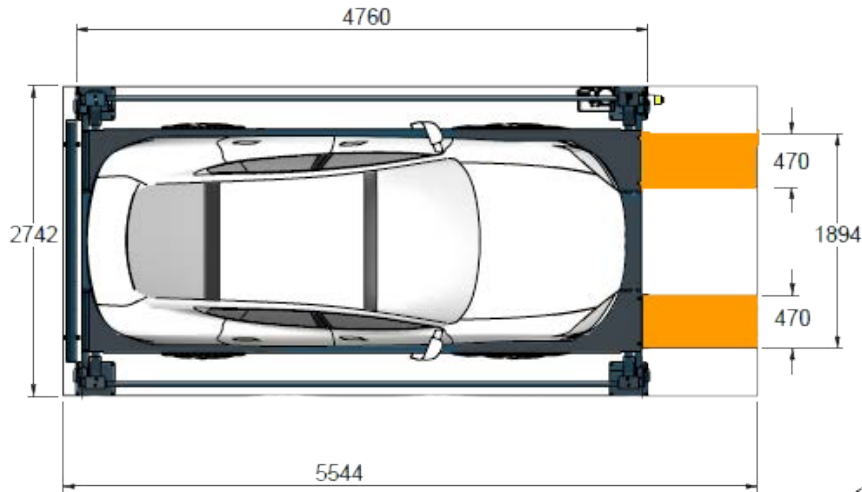
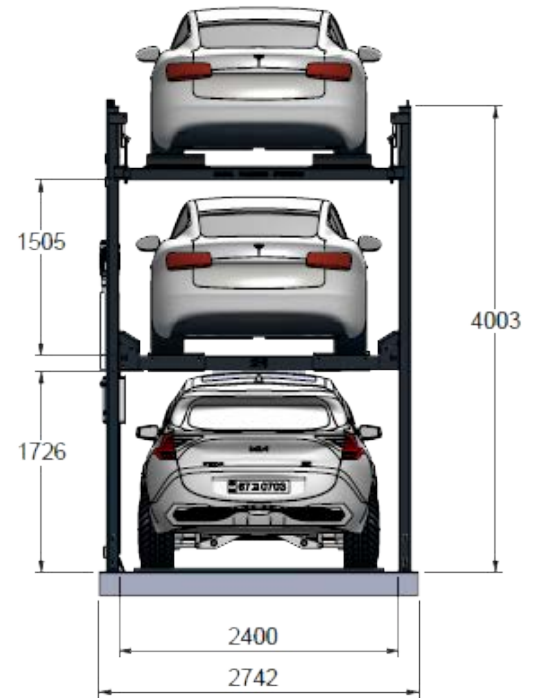
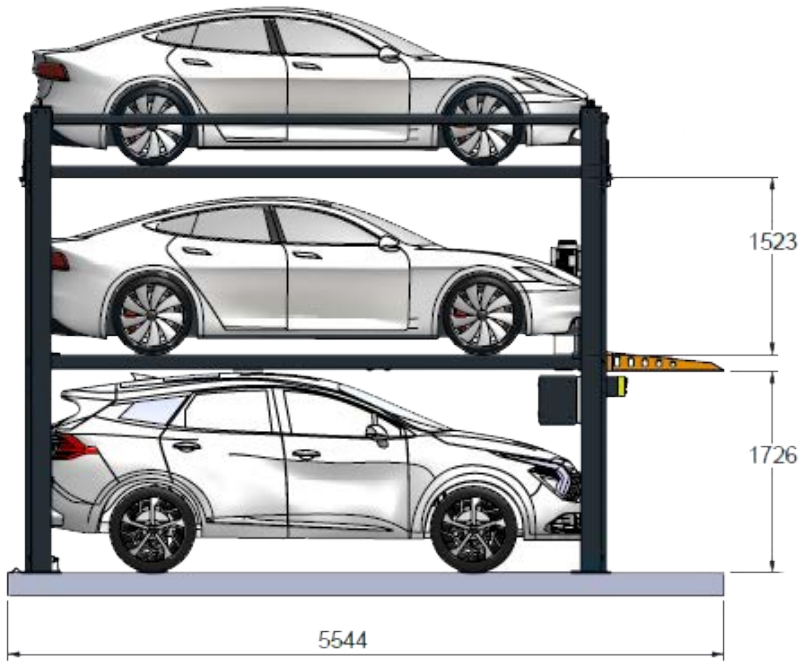

Model Type No.	Car Weight	Unit Height	Power Supply	Motor Capacity
TSL 2.7T3500	2700 Kg	4000 mm	220 V or 380 V	3 Kw

# Hydraulic Four Post Car/Cargo Elevator



## PRODUCT FEATURES

- Floor mounted 4 post heavy duty car elevator for outdoor use.
- Customized design based on requested lifting height, lifting capacity and number of stops.
- Hydraulic driven system through horizontal cylinder mounted on the side beam.
- Double chain lifting system connected to the cylinder for lifting the platform from left side.
- Couple chain balance system for both front & back sides ensure the platform deck remains levelled throughout the vertical travel, even with off-centered loads.
- Hydraulic power unit and electric panel are protected inside ergonomic compact size console with portable operation box.
- Side barrier fences fixed on the platform deck sides to ensure safety and visibility.
- Thick reinforced steel platform minimizes deflection and maximizes stability.
- Ideal for lifting cars among ground, upper & lower levels at different heights.
- The standard finishing is sandblasting then painting 2 layers (primer & finish coat) with SAWA standard colors (RAL 7015 Slate grey & RAL 1028 Melon yellow).



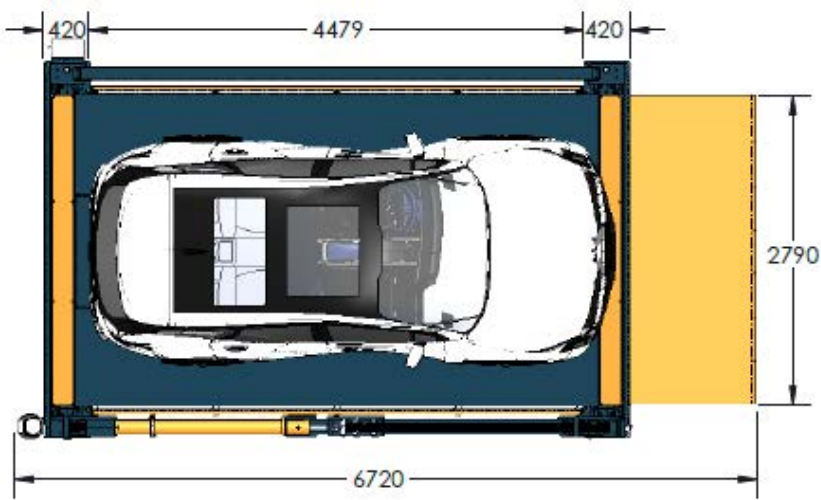
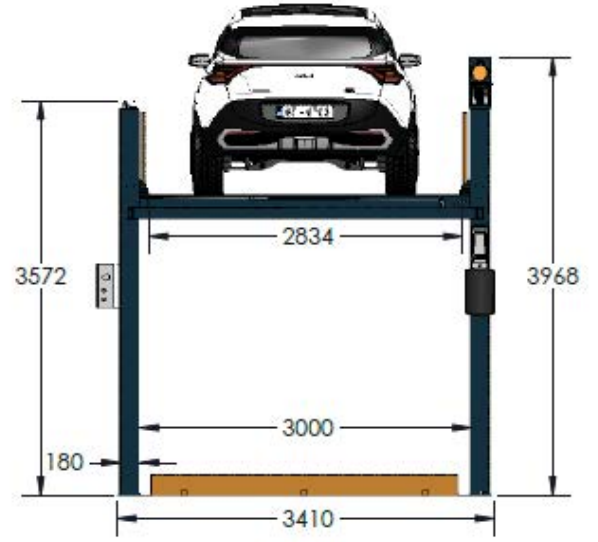
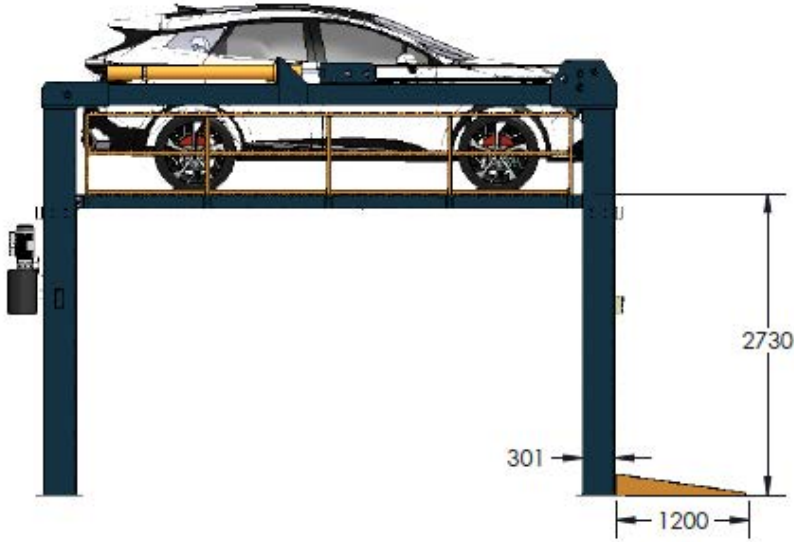

Model Type No.	Car Weight	No. of Stops	Power Supply	Motor Capacity
FPE 4T2730	4000 Kg	Ground+1	380 V	3Kw - MOTOR
Note	Customized product with variable dimensions & specs. per request			

# Hydraulic Scissor Car/Cargo Elevator



SPS

## PRODUCT FEATURES

- Elevator with scissor mechanism, driveway platform and hydraulic lifting system to move Cars/Cargo between different levels.
- Saving space by avoiding traditional concrete ramps to reach multiple levels with different lifting heights.
- Can be tailored and customized according to dimensions, lifting height, lifting capacity etc.
- Can be integrated with sliding platform to move car in and out of the lift, can be embedded with a turn table to change the car direction in entry and exit, can be with a canopy designed to be paved with various materials to match the surrounding ground and landscape.
- Hydraulic power unit of different capacities according to design, oil tubes and valves.
- Manual oil drain valve to lower the scissor manually when power off.
- Hydraulic cylinders equipped with hose rupture valves to prevent back flow of pressurized oil in the system after the valves.
- dead man pushbuttons operation box with emergency stop & on/off key switch and can be operated with remote control (optional).
- One-piece base frame with scissor arms (single or double depending on lifting height) makes it easy for loading & offloading horizontally by crane.
- Adjustable limit switch at every level to ensure stopping the platform(s) at predefined height.
- Anti-fall safety locking system to be activated automatically at each level with Electromagnetic lock release.
- The standard finishing is sandblasting then painting 2 layers (primer & finish coat) with SAWA standard colors (RAL 7015 Slate grey & RAL 1028 Melon yellow).

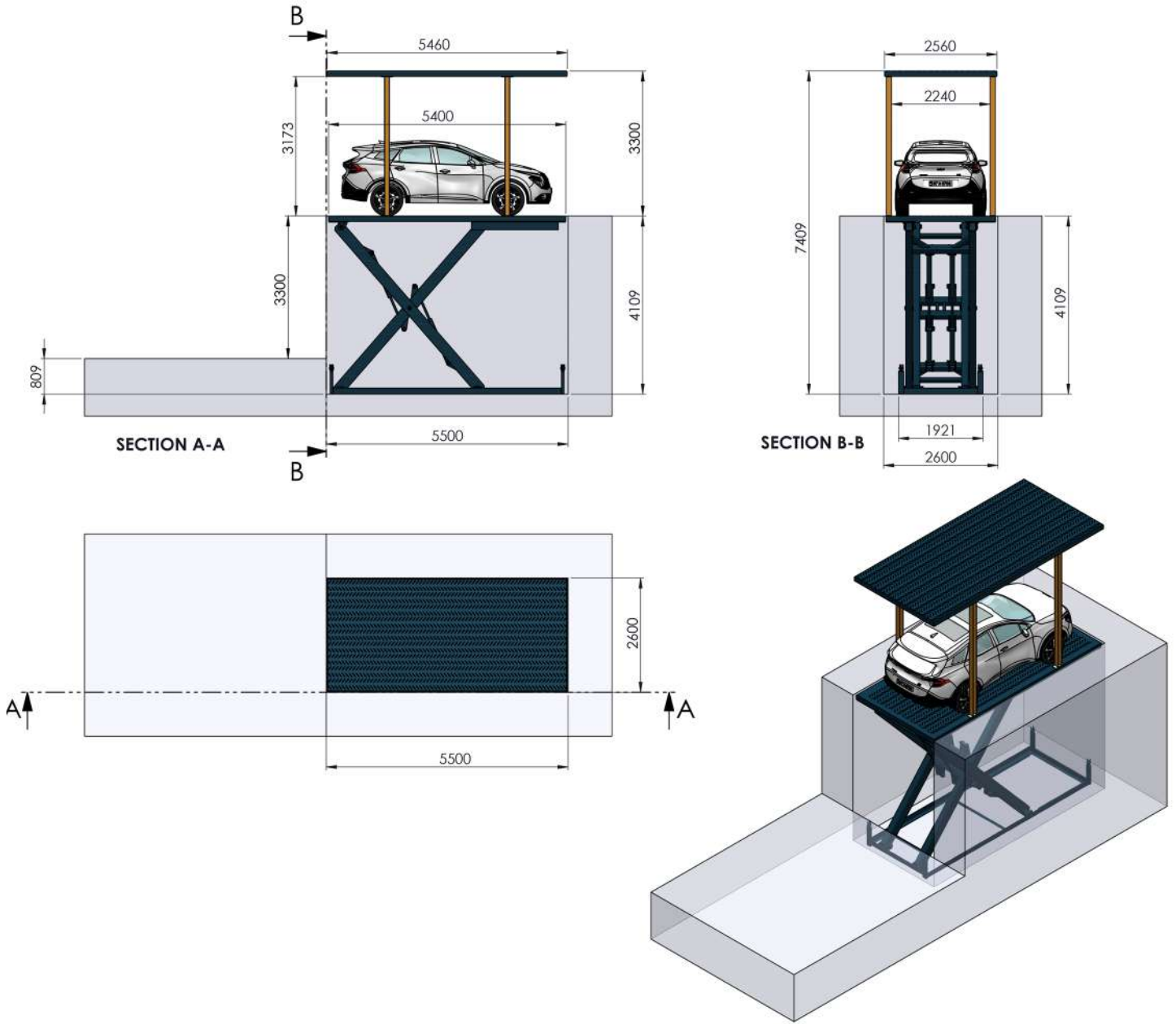

Model Type No.	Car Weight	Unit Height	Power Supply	Motor Capacity
SPS 2.5T3300	2500 Kg	7409 mm	380 V	5.5 KW

**Scissor lift with turn table**

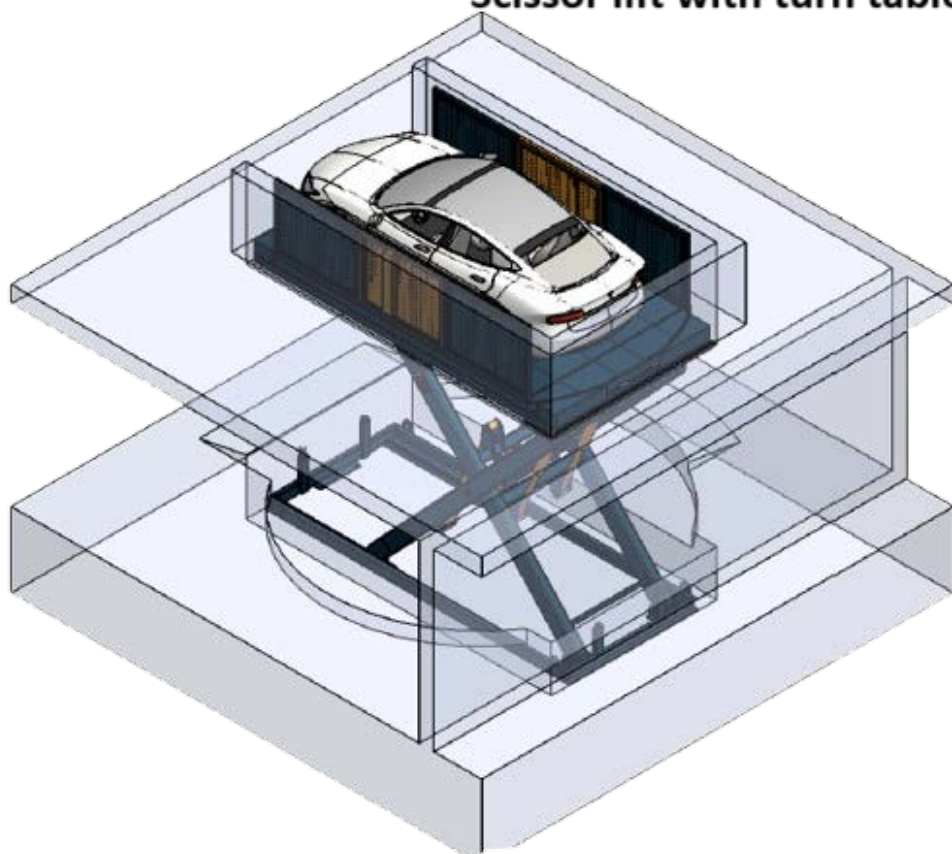

**Scissor lift with canopy & extra platform**

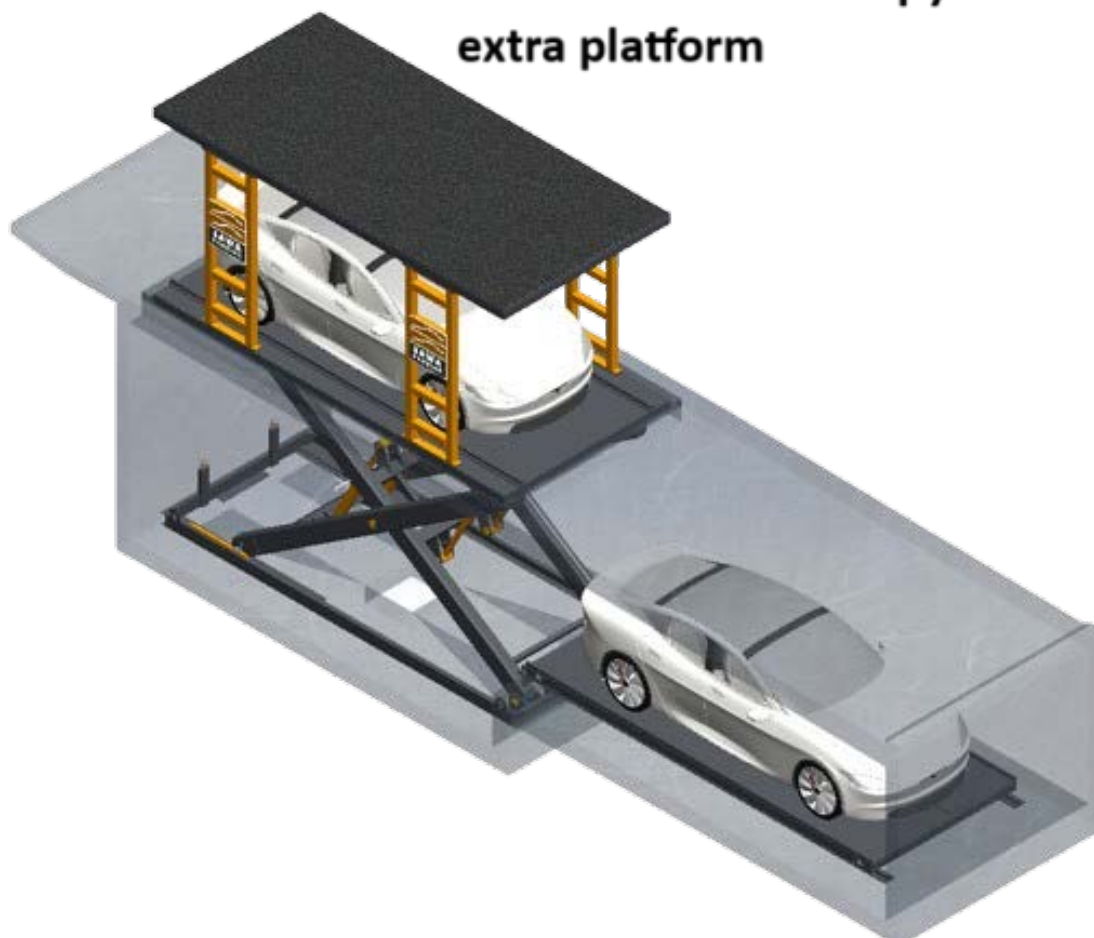



Scissor lift with canopy



Double Stage Scissor



# Geared Motor with Rack & Pinion Car/Cargo Elevator



## PRODUCT FEATURES

- Floor & wall mounted two post heavy duty car elevator to be installed inside the shaft.
- Customized design based on requested lifting height, lifting capacity and number of stops.
- Geared motor driven system through Rack & Pinion to achieve steady move of platform without vibration.
- Platform balancing is guaranteed by using wheels as a combined bearing inside C beams.
- Electric geared motor is mounted under the platform, connected with transmission shaft.
- Side barrier fences fixed on the platform deck sides to ensure safety and visibility.
- Operation through man on board kit fixed to side barrier & remote control.
- Thick reinforced steel platform minimizes deflection and maximizes stability.
- Ideal for lifting cars among ground, upper & lower levels at different heights.
- Electromagnetic lock to be engaged inside safety ladders fixed to side posts.
- The standard finishing is sandblasting then painting 2 layers (primer & finish coat) with SAWA standard colors (RAL 7015 Slate grey & RAL 1028 Melon yellow).

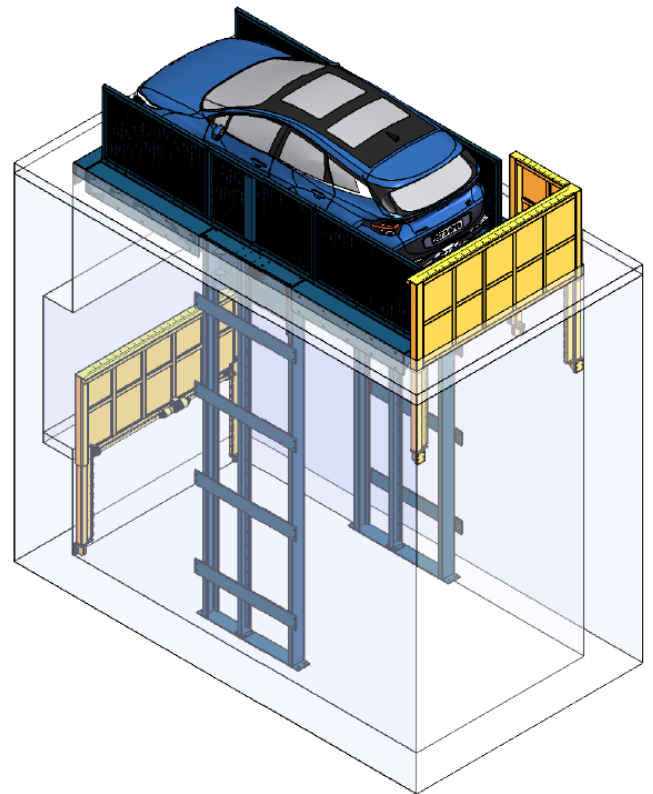
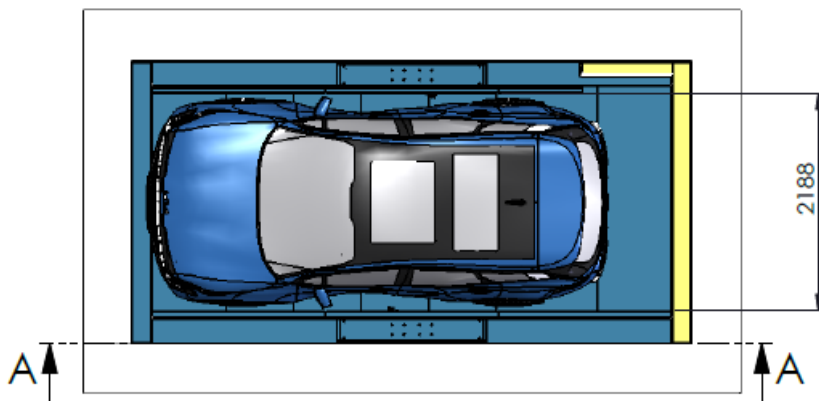
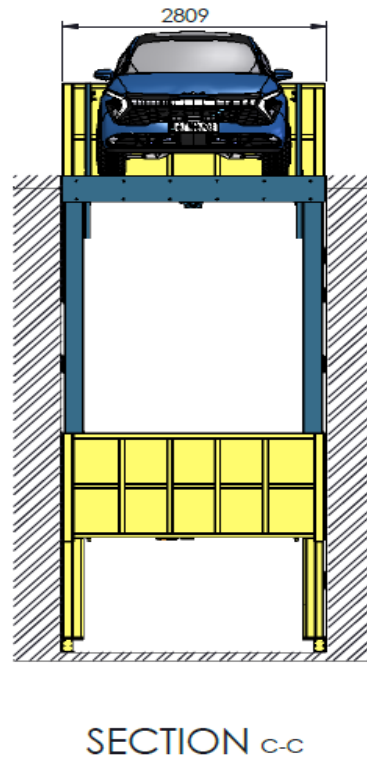
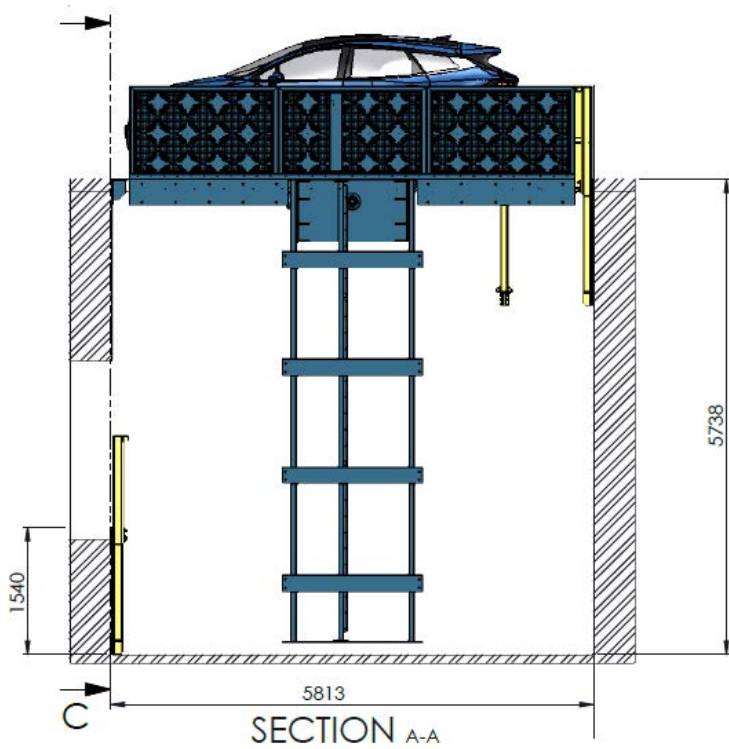

Model Type No.	Car Weight	Stroke	Power Supply	Motor Capacity
GME 3T4000	3000 Kg	Customized	380 V	3 KW

# Puzzle Parking System



## PRODUCT FEATURES

- Motor driven and roller chain or steel rope lifting system.
- Space saving with multiple vertical levels and multiple horizontal bays. Each level has an empty parking space through which the outgoing car is passing when it called except the top level and the lower under ground level (if applicable). This process is performed by front-rear guide rails through which the platforms move horizontally.
- Top level and lower under ground level (if applicable) platforms can only move vertically while the ground level platforms can only move horizontally. Other levels platforms can move both horizontally & vertically to prepare the right way for incoming and outgoing cars.
- Multiple security protection devices to prevent falling, collision and overload. Besides photo electric sensors to check and stop the unit when cars park improperly or when persons accidentally cross in.
- Emergency stop push button mounted on operation panel as well.
- PLC automatic control system. Push button, touch screen and IC for convenient parking and retrieving process.
- The standard finishing is sandblasting then painting 2 layers (primer & finish coat) with SAWA standard colors (RAL 7015 Slate grey & RAL 1028 Melon yellow).



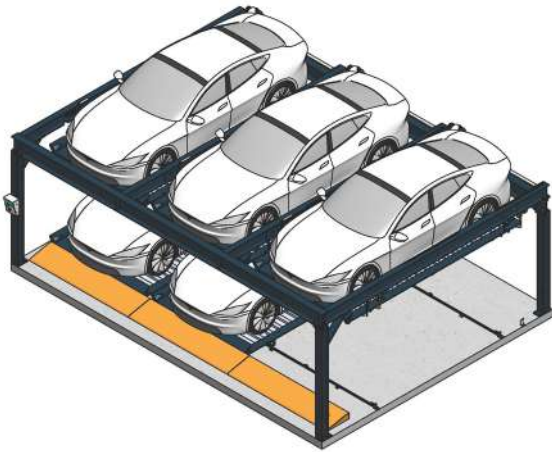

Puzzle 5 cars (3 bays / 2 levels)

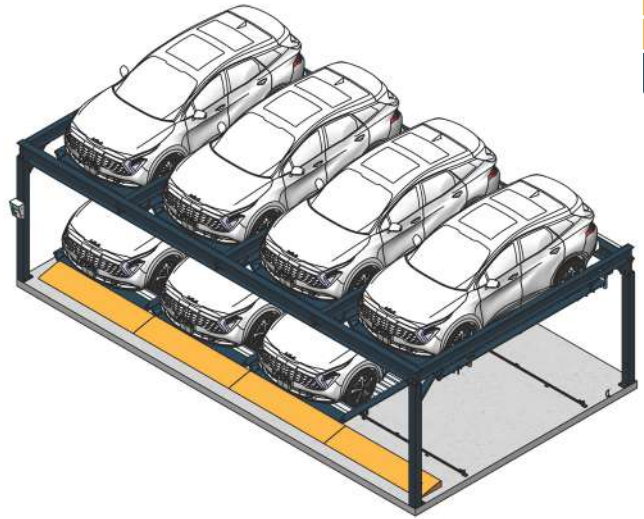

Puzzle 7 cars (4 bays / 2 levels)

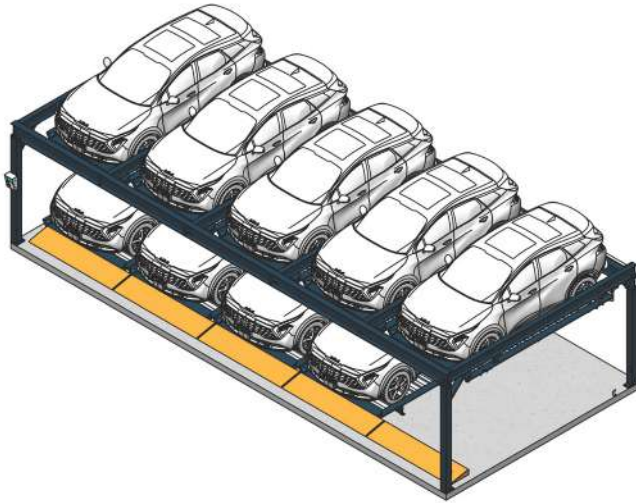

Puzzle 9 cars (5 bays / 2 levels)

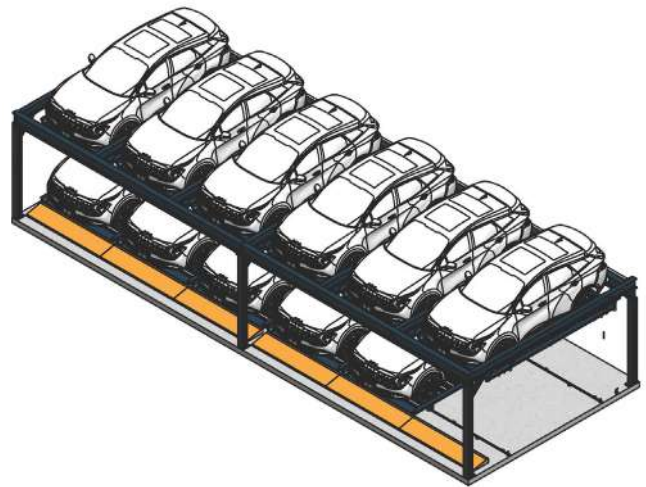

Puzzle 11 cars (6 bays / 2 levels)

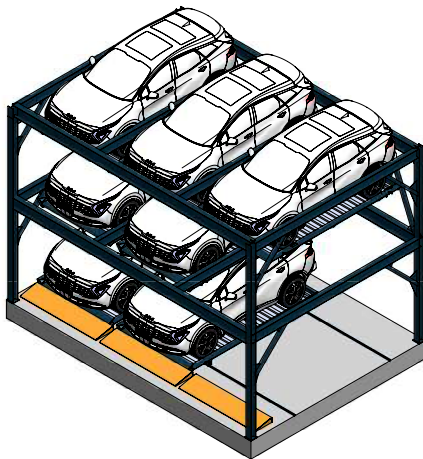

Puzzle 7 cars (3 bays / 3 levels)

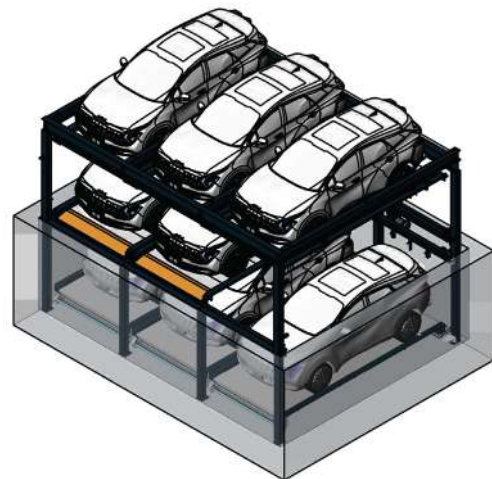

Puzzle with pit 8 cars (3 bays / 3 levels)

Lifting Capacity	Drive Mode	Power Supply	Lifting Motors	Sliding Motors
2150 Kg	Motor + chains	380 V/3Ph	2.2 KW	0.2 KW

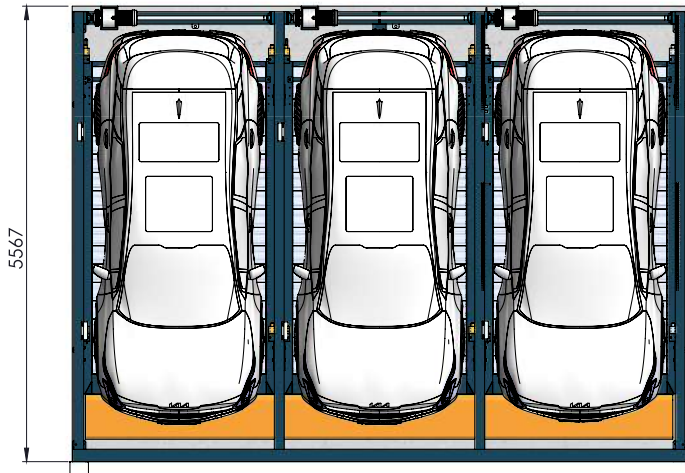
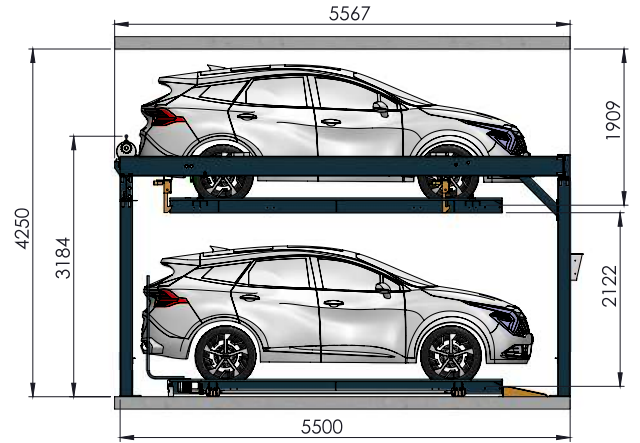
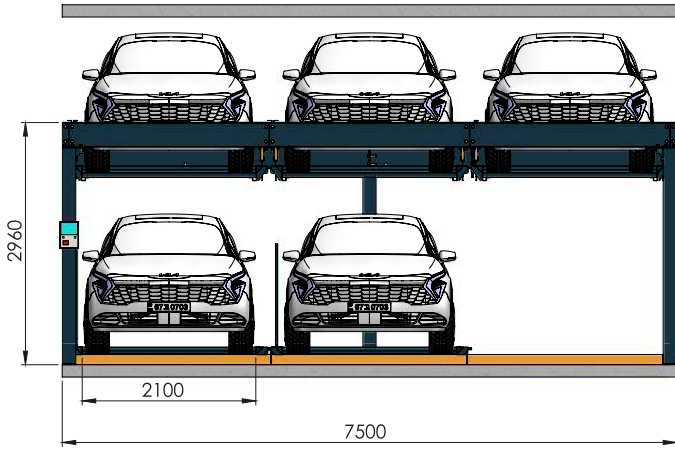

Puzzle 5 cars SUV

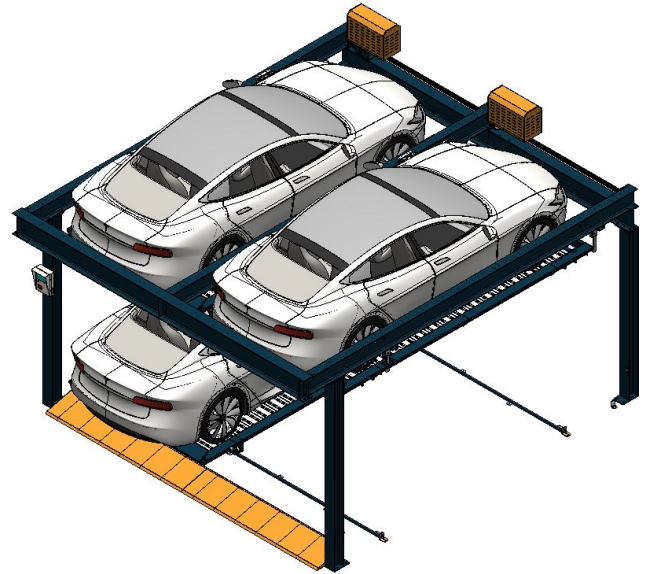

Puzzle 3 cars

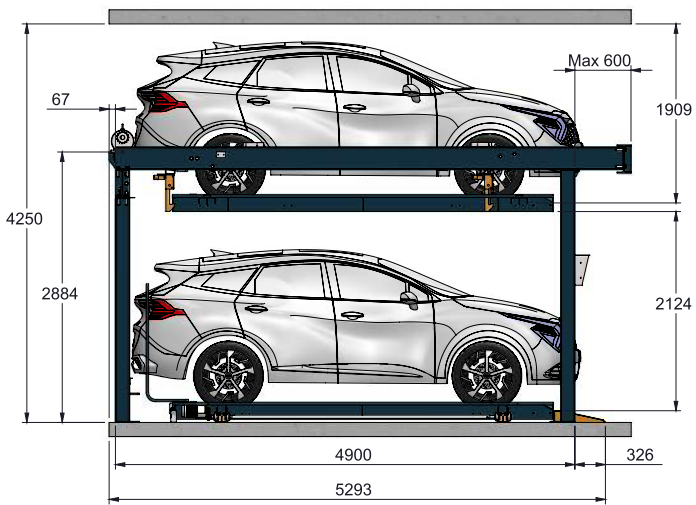

Puzzle 5 cars cantilever SIDE-VIEW

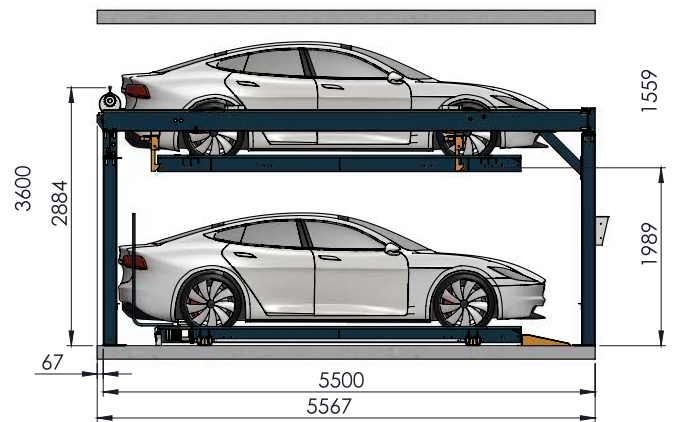

Puzzle 5 cars sedan SIDE-VIEW



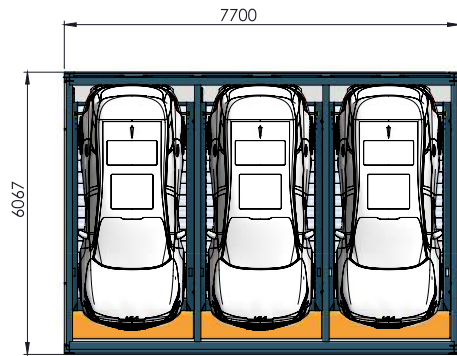
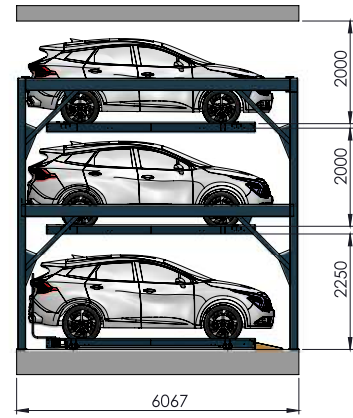
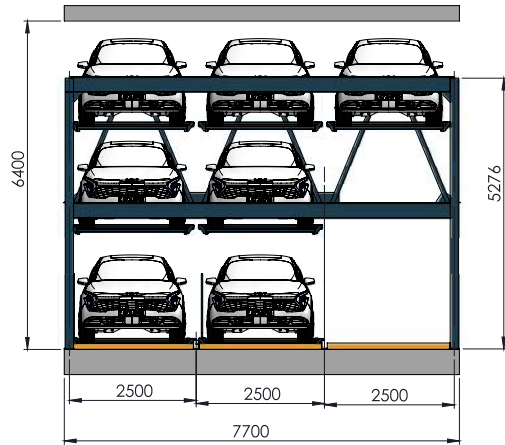

Puzzle 7 cars 3 levels

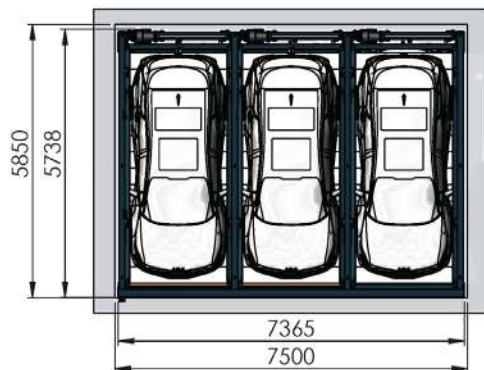
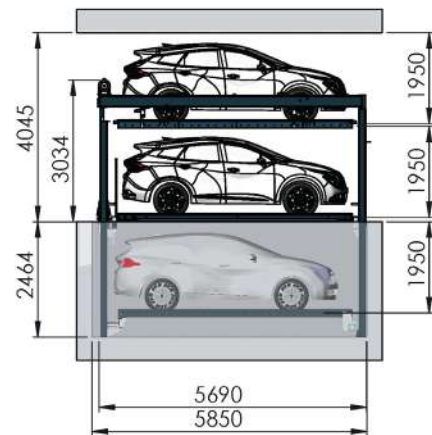
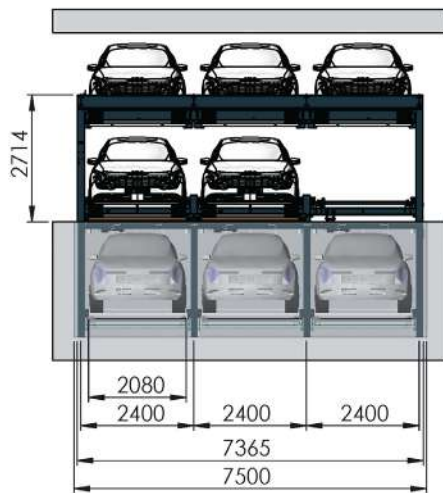

Pit Puzzle 8 cars

# Rotary Parking System



RPS

## PRODUCT FEATURES

- Motor driven, chain lifting system.
- Designed to park vehicles by vertically circulating cage in CW/CCW directions.
- The most space efficient parking solution as you can park up to 16 cars in small area doesn't exceed 2 cars.
- Simple one-touch control and doesn't require professional operator. Intelligent rotation direction (in CW/CCW) to shorten entry / exit time.
- PLC automatic control system, touch screen to call the required vehicle in one touch.
- Different models to park 8, 10, 12, 14 & 16 cars depending on available heights, car type and customer request.
- The standard finishing is sandblasting then painting 2 layers (primer & finish coat) with SAWA standard colors (RAL 7015 Slate grey & RAL 1028 Melon yellow).



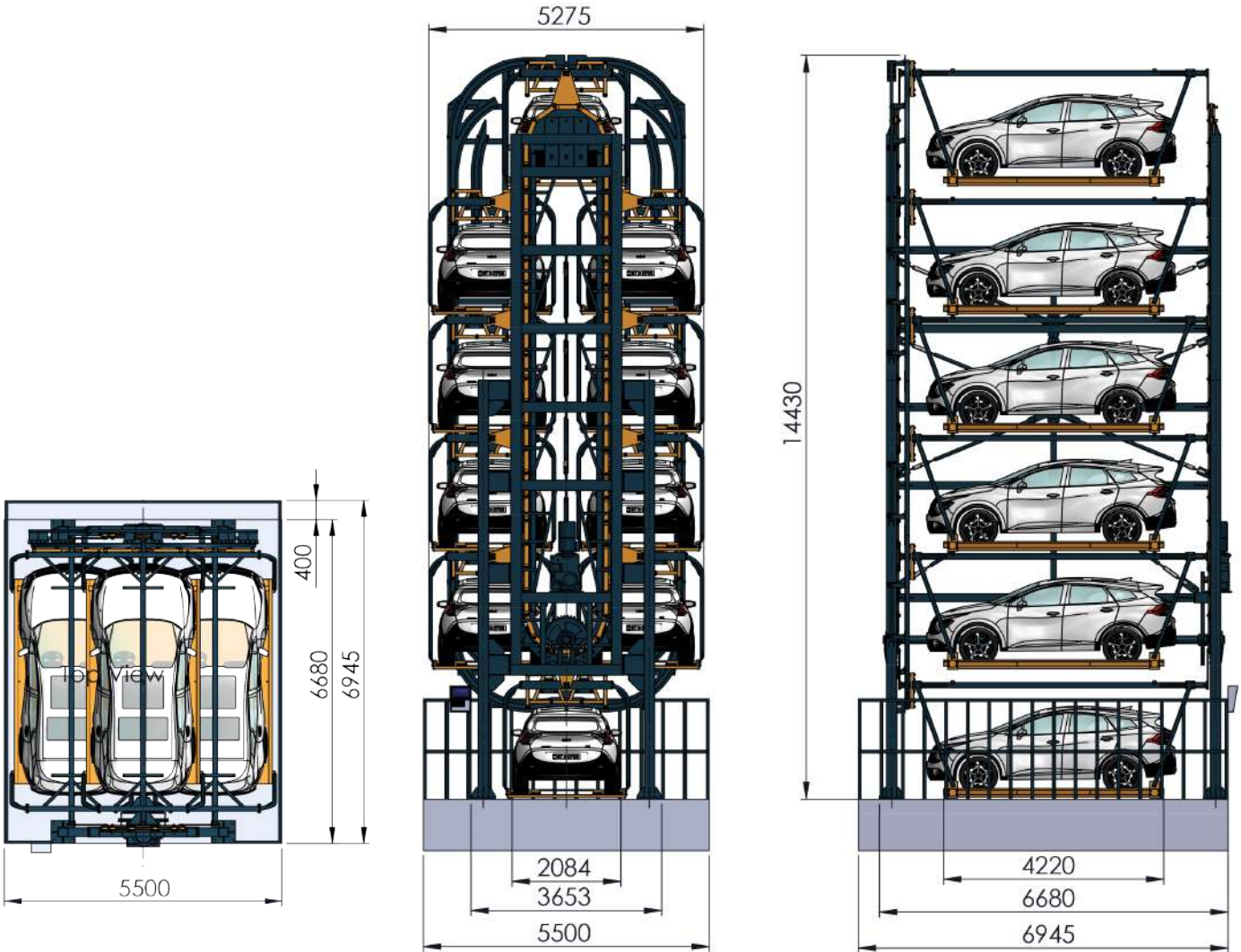

Model Type No.	Car Weight	Height	Power Supply	Motor Capacity
RPS 2.1T10	2150 Kg	14430 mm	380 V	11 KW
RPS 2.1T12	2150 Kg	16730 mm	380 V	15 KW

# Car Space Block



## PRODUCT FEATURES

- High quality steel structure
- Strong and durable
- Easy to operate manually without electric power need
- Lock with key
- Simple and beautiful design
- Suitable for indoor, outdoor, commercial and private use

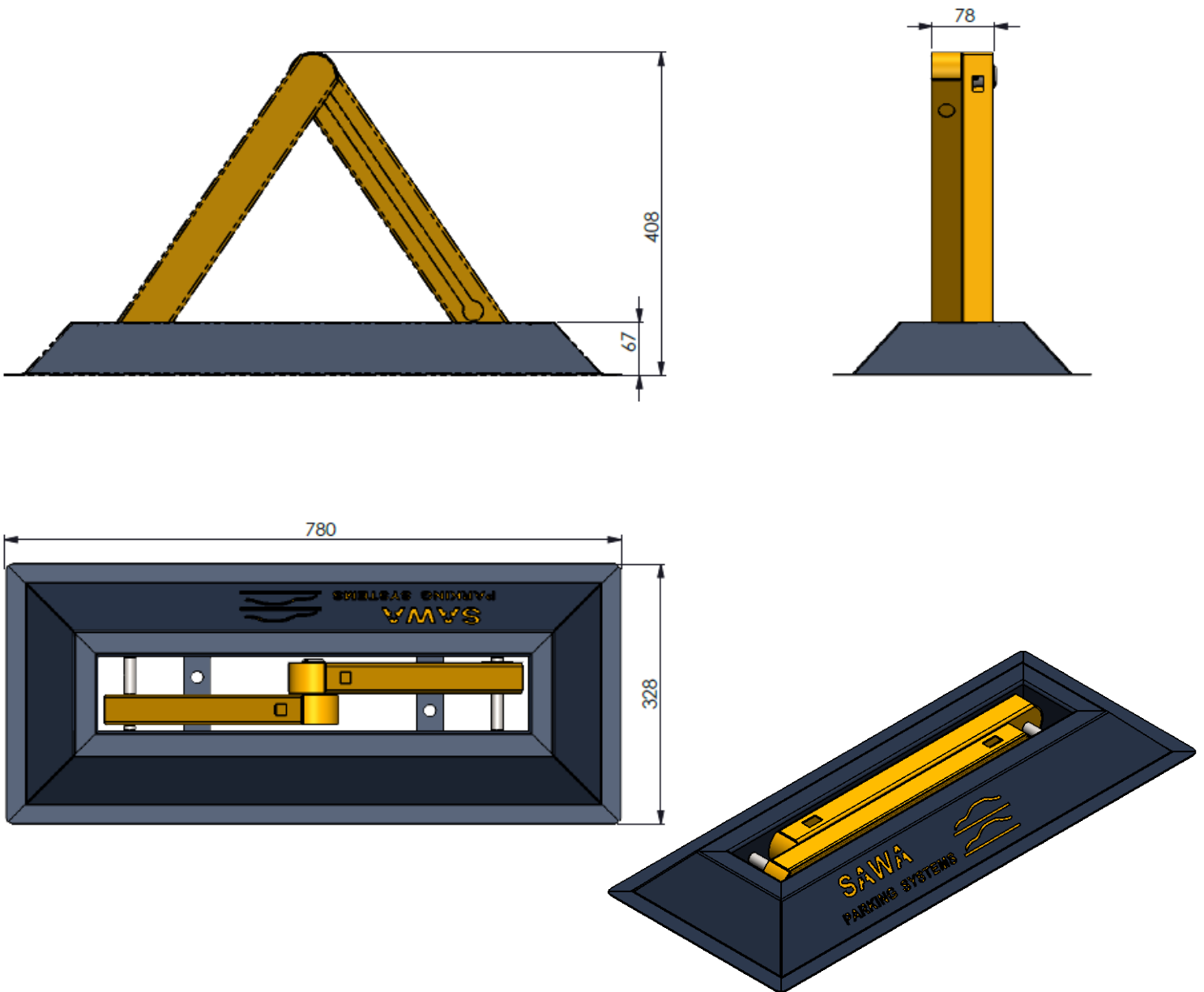

Model Name	Over All Dimensions			Weight
Car Space Block	L 780 mm	W 328 mm	Hight: opend 408 mm closed 67 mm	10KG



+20 10 1511 1174 / +20 15 5597 5758  
+20 5543 33555 / +20 5543 33666

info@sawaparking.com  
www.sawaparking.com

Plot 88 & 89, Industrial Area A4',  
10th of Ramadan City, Egypt

    SAWA Parking Systems